



MODEL S-RD-I

TRUE ROUND - LOW LEAKAGE SMOKE DAMPER

U.L. 555S CLASSIFIED AND ULC S112.1 LISTED

Class I Leakage Rated

Application and Design

The Model S-RD-I is a UL/ULC listed and labeled Class I leakage rated True Round Smoke Damper. Blades are of the double thickness, round design. The damper is approved for airflow in either direction and provides a maximum leakage of 8 cfm/sq. ft at 4" wg. s.p. It has been designed to be installed in a vertical or horizontal mounting position in the ductwork or a separate sleeve within 24" of the smoke partition. These dampers are approved for use in engineered smoke control systems and are controlled via smoke detection system. Electric (24v, 120v, and 230v) or pneumatic actuators are used to operate the smoke dampers.



U.L. 555S CLASSIFIED AT 250°F OR 350°F DEPENDING UPON MOTOR/OPERATOR *SEE MOTOR/OPERATOR SCHEDULE

Standard Construction

Frame: Roll formed Frame - Galvanized Steel - 16" Integral Sleeve

Blades: Double thickness galvanized Steel of roll-formed construction.

Axles: Square plated steel

Seals: Pressure Sensitive 450° silicone blade edge seals and flexible metal jamb seals.

Linkage: Jackshafted to blade

Bearings: Bronze Oilite press-fit into frame

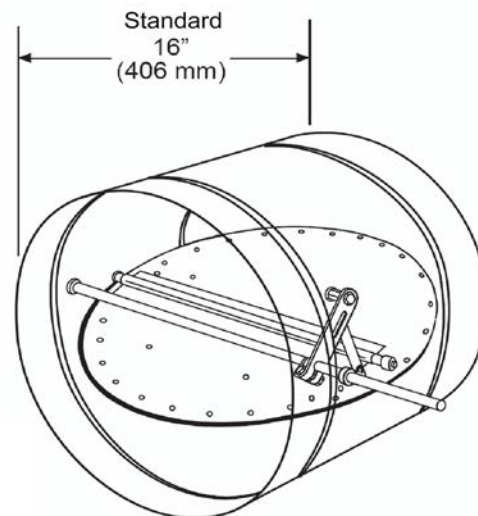

Designed and tested in accordance to standards: UL 555S, ULC S112.1. Labeled and listed by UL/ULC under File # R25410. They meet all the NFPA-90A, IBC Code, and other major code requirements for Smoke Dampers.

Transitions can be added to the ends of the damper to accept ductwork down to 4" in diameter.

| Standard Sizes (duct) | |
|-----------------------|---------------|
| Min. V or H | |
| 8" - 24" Diameter | 203mm - 610mm |

Options:

- Electric Actuator, _____ VAC
- Pneumatic Actuator, 25 psi
- Extended Sleeve, _____ inches, 16" min.
- Smoke Detector*
 - Ionization
 - Photoelectric
- *Must have 24" Sleeve
- Micro-Switch Package

Notes:
• Dampers are provided approx. 1/8" (3.2mm) smaller than given duct dimensions.
• Not recommended with blades running vertically.

Suggested Specification

Low Leakage Smoke Control Dampers shall be Model:S-RD-I by United Enertech. Single blade edge seal shall be of the pressure sensitive type for low leakage. Dampers shall be rated for leakage as to U.L. 555S / U.L.C. S112.1 rating shall be Class I with leakage not to exceed 8 cfm per sq. ft. at 4.0 inches static pressure. Linkage shall be jackshafted to the blade.

Manufacturer's Recommendations

All moving parts of the damper must be inspected and cycled at intervals not greater than every 12 months or in accordance with the latest edition of NFPA 90A, 92A, local codes and the actuator manufacturer. In addition, fuse links shall be removed and inspected for corrosion. Dry lubricants are recommended.

| |
|-------------|
| Job Name: |
| Location: |
| Architect: |
| Engineer: |
| Contractor: |

| | | |
|---------------------------------------|---------------------|-----------------------|
| <input type="checkbox"/> MODEL S-RD-I | | |
| DRAWN BY: MAB | DATE: 11-07-07 | REV. DATE: 9-12-11 |
| REV. NO. 5 | APPROVED BY: SDC | DWG. NO.: C-5 |